



LM500-D Series

LM500-D Series combines technology warning light and siren Solaris compact LEDs manufactured in ABS with fiberglass and aluminum.

Optical system composed of a microprocessor integrated electronic circuit, 15 high intensity LEDs and a parabolic reflector maximizes light intensity of LEDs and avoids the appearance of black shadows.

His acoustic system consisting of a 30W speaker, with programmed wail tone, with a cigarette lighter socket 3 positions.

A wire mesh filter prevents the ingress of solid particles by the broadcaster of the siren, a drainage system prevents the accumulation of water in the membrane and a rubber gasket prevents water ingress into the electronic circuitry.

LM500-D Solaris, has a magnet system with a set of 4 magnets with silicone anti-scratch protection and 4 cups.

Available in blue, amber or red LED.

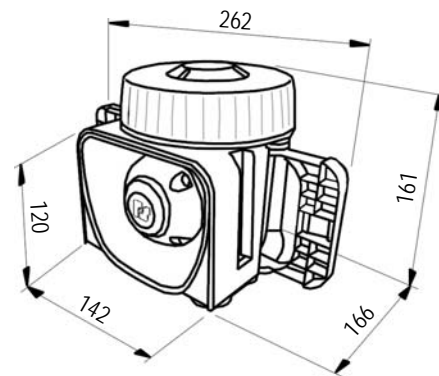

LM500-D Solaris Series dimensions (mm).

Voltage:	12 V
Light current consumption:	0.6 Amp
Siren current consumption:	3 Amp
Siren output power:	30W
Siren output voltage:	23 V
Operating temperature:	-20°C to 50°C
Weight:	2.28 kg

REF.	MOD.	DESCRIPTION
------	------	-------------

	2003049	LM500-D	Solaris LED warning light blue with integrated 30W siren. Cigarette plug w/ 3 positions for light and siren control, wail tone, 12V. UN R65 Approval T Category
	2003048	LM500-D	Solaris LED warning light amber with integrated 30W siren. Cigarette plug w/ 3 positions for light and siren control, wail tone, 12V. UN R65 Approval T Category
	2003050	LM500-D	Solaris LED warning light red with integrated 30W siren. Cigarette plug w/ 3 positions for light and siren control, wail tone, 12V. UN R65 Approval T Category

*Maximum speed for this model on the roof of the vehicle 200 km/h.

** For other tones, please contact with the Sales Department.

*** Magnetic mounting models produced for a temporary use on the roof of the vehicle.