

TRIDENT II Series



Federal Signal Vama presents the new **Trident II Solaris** beacon family including high-performance, durable also a quick & easy installation beacons for effective hazard warning and search lights.

The Trident II Solaris models are suitable for priority warning, or they can be combined with lightbars to increase the emergency lighting efficiency. The lens is manufactured in durable shockproof polycarbonate and the base is made from reinforced polyamide.

The Trident II Solaris family consists of Solaris LED and search lights.

The Solaris technology means born under the ultimate influence of sun. Solaris provides an exceptional light beam with superior off-axis warning and eliminates any dark spots.

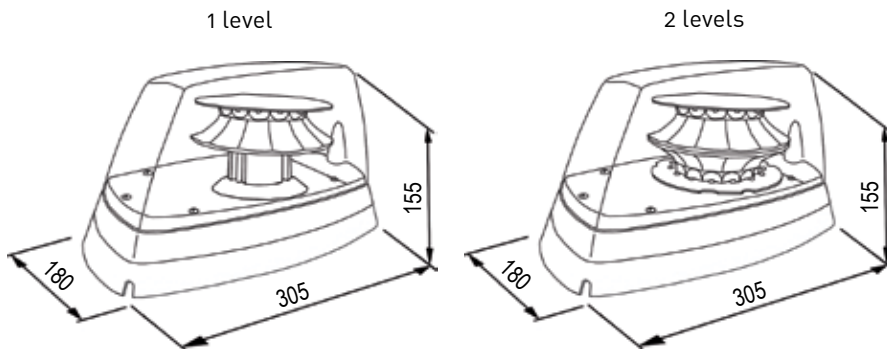

Trident II Solaris dimensions (mm).

Voltage:	10-30 V
Operating temperature:	-20°C to 50°C
Average consumption:	Blue or red with 1 level 1 Amp (12V) Amber with 1 level: 0.6 Amp
Leds colours:	Blue, amber, red
Lenses colours:	Blue, amber, red
Dimensiones:	180 x 305 x 155 mm
Weight:	1100 g (2 levels)

REF.	MOD.	DESCRIPTION
------	------	-------------

Trident II Solaris

2010476	TRIDENT II SL	(1) level, 15 high-intensity LEDs with parabolic reflector, high intensity, blue LEDs, permanent mount, multivoltage. R65 Approved
2010475	TRIDENT II SL	(1) level, 15 high-intensity LEDs with parabolic reflector, high intensity, amber LEDs, permanent mount, multivoltage.
2010474	TRIDENT II SL	(1) level, 15 high-intensity LEDs with parabolic reflector, high intensity, red LEDs, permanent mount, multivoltage.
2010499	TRIDENT II SL	(2) level, 15+15 high-intensity LEDs with parabolic reflector, (2) levels of light intensity (day/night), blue LEDs, permanent mount, multivoltage. R65 Approved Class 2
2010501	TRIDENT II SL	(2) level, 15+15 high-intensity LEDs with parabolic reflector, high intensity, amber LEDs, permanent mount, multivoltage.
2010500	TRIDENT II SL	(2) level, 15+15 high-intensity LEDs with parabolic reflector, high intensity, red LEDs, permanent mount, multivoltage. * Base mouting kit for Trident II must ordered (see accessories).

Trident II Search Light

2010538	TRIDENT II FB	55W search light, home position feature, permanent mount, 12V (remote control head must be ordered separately).
2010600	TRIDENT-FB LEDS	TRIDENT II LED search light, permanent mount, 12V (remote control head must be ordered separately) * Base mouting kit for Trident II must ordered (see accesories).
8216151	MC-TRIDENT II FB	Remote control head with spiral cable, 12V

Accessory

2010546		Base mouting kit for Trident II
---------	--	---------------------------------