

LE106 Series

This series stands out for its high-efficiency strobe warning lights with Xenon lamps and bivoltage power supplies with a flash frequency of 120 fpm.

The beacon has a double lens system for light dispersion, colour and protection. The inner Fresnel lens distributes the light. The outer lens in different colours protects the unit and serves as waterproof cover.

The LE106 series consists of the following models:

- **LE106DCH:** Strobe beacon with lamp failure detection, low intensity, synchronised function option, optional cruise light and permanent mount.

- **LE106CH/MAG:** Strobe beacon with magnetic mount, suction pads and cigarette plug.

- **LE106HE:** Best value strobe beacon with permanent mount.

It is possible to install these beacons either on surface or on a DIN tube with connector.

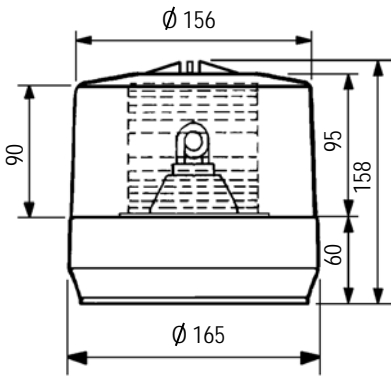

LE106 Series dimensions (mm).



Voltage:	Bitension (12 / 24 V)
Average consumption:	12V: 2.3 Amp 24V: 1.4 Amp
Strobe lamp:	35 W
Dimensions:	165 (diameter) x 158 mm
Weight:	800 g



BD-106 Base adapter



M-106 Adapter base joint, slopy surfaces (angles up to 4°).



AD-015 Adapter base joint, slopy surfaces (angles up to 4°).



JB-015 Adapter base joint, curved surfaces.

REF.	MOD.	DESCRIPTION
2002349	LE-106HE	Strobe beacon, double lens, permanent mount, blue, bitension. UN R65 approved
2002350	LE-106HE	Strobe beacon, double lens, permanent mount, amber, bitension. UN R65 approved
2002388	LE-106HE	Strobe beacon, double lens, permanent mount, red, bitension
2002314	LE-106DCH	Strobe beacon, double lens, 15J, failure detection, synchro, w/ power supply, permanent mount, blue, bitension. UN R65 approved
2002319	LE-106DCH	Strobe beacon, double lens, 15J, failure detection, synchro, w/ power supply, permanent mount, amber, bitension. UN R65 approved
2002312	LE-106CH	Strobe beacon, double lens, 15J, w/ power supply, permanent mount, blue, bitension. UN R65 approved
2002311	LE-106CH	Strobe beacon, double lens, 15J, w/ power supply, permanent mount, amber, bitension. UN R65 approved
2002337	LE-106CH/MAG	Strobe beacon, double lens, 15J, w/ power supply, magnetic mount, blue, bitension. UN R65 approved
2002338	LE-106CH/MAG	Strobe beacon, double lens, 15J, w/ power supply, magnetic mount, red, bitension

Mount Accesories

8232386	BD-106	DIN 14620 Mount kit, LE-106
9133996	AI-106	Adaptor ring for roof inclination, LE-106DCH
8232387	BD-015	Base adapter, DIN pipe mount ISO4148, LR-015 and LE-106HE
9133980	JB-015	Adapter base joint for LR-015 and LE-106HE
9133981	M-106	Adapter base joint for LR-015 and LE-106HE on slopy surfaces (angles up to 4°)
9133997	AD-015	Adapter base joint for LR-015 and LE-106HE on slopy surfaces (angles up to 4°)
9133924	M-106	Adapter base joint for LE-106DCH