



## VIPER S2 SOLARIS



The new **VIPER S2** LED lights provide, with the Solaris exclusive technology from Federal Signal Vama, the ideal solution for camouflaged vehicles or reinforce the lighting on emergency vehicles. Viper S2 Solaris is windshield mount. Main advantages are:

- **HIGH INTENSITY.** Thanks to LED Solaris technology, its spread lens and special light inclination. Molded scalloped facets at the rear of the reflector direct LED light forward to form an impressive block of illumination. Two inboard side reflectors mirror high intensity LED light to the side producing wide-angle off-axis warning. Combined, the Viper S2 delivers the most effective compact, lightweight warning light available.
- **USER FRIENDLY.** Plug & Play connection, through cigarette plug with a 2,7 m cable. Flash patterns could be changed just pushing a button.
- **EASY, VERSATILE INSTALLATION.** Specially designed to be quickly mounted, with a minimum manipulation. Thanks to its compact dimensions, it could be installed on every part of the vehicle.
- **LOW AMP DRAW AND LONG LIFE.** Optimizes vehicle battery performance.

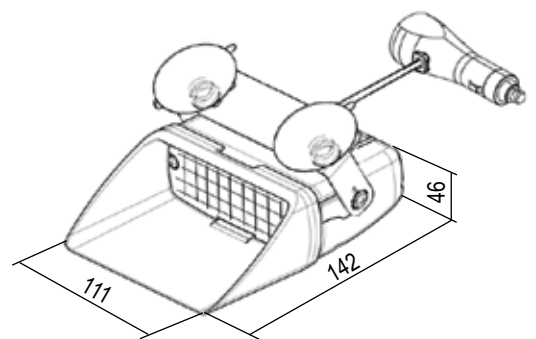

Viper S2 Solaris dimensions (mm).

Voltage:	12V
Average consumption:	1Amp blue and red 0.75 Amp amber
Operating temperature:	-20°C to +50°C
Dimensions:	111 x 46 x 142 mm
Weight:	300g

REF.	MOD.	DESCRIPTION
2010549	VIPER S2 Solaris	VIPER S2 SINGLE Solaris, blue LED and spreader clear lens, 5 flash patterns, cigarette plug, windshield mount, 12V, R65 approval.
2010548	VIPER S2 Solaris	VIPER S2 SINGLE Solaris, amber LED and spreader clear lens, 5 flash patterns, cigarette plug, windshield mount, 12V, R65 approval.
2010550	VIPER S2 Solaris	VIPER S2 SINGLE Solaris, red LED and spreader clear lens, 5 flash patterns, cigarette plug, windshield mount, 12V.