



DYNAMAX™ / ES100C SPEAKERS



Sleek Design Meets High-Performance

The DynaMax, ES100C, is a 100-Watt speaker designed to withstand the toughest conditions. The ES100C features the Federal Signal Neodymium driver for increased performance and reliability.

The ES100C housing is molded from composite plastic — 30% glass-filled PET (polyethyleneterephalate). This high-strength composite material provides good chemical resistance and maintains rigidity at high temperatures.

A variety of vehicle specific ES100C mounting brackets are available to make installation simple.

> Features

- 100-Watt compact speaker.
- Neodymium driver.
- Slim and lightweight.
- Easy to install and maintain.
- Can be used on large apparatus, ambulances, law enforcement vehicles, and command fleet.
- Durable and reliable.
- Two year speaker warranty.

> Approval

- SAE and CCR specifications when paired with Class A Federal Signal amplifier and electronic siren.

> How to Order

Select Model

ES100C Speaker, 100-Watt, high-output
ES100C-DEU Speaker, 100-Watt, high-output with Deutsch connector

DynaMax/ES100C Brackets

ESB-U Universal bail bracket, all vehicles
ESB-V08 Ford Crown Vic Interceptor, 2002-2011
ESB-TAH08 Chevrolet Tahoe, 2008-2014
ESB-IMP08R Chevrolet Impala, 2006-2014
ESB-EXP07 Ford Police Interceptor Utility, 2013-2014
ESB-CAP11 Chevrolet Caprice, 2011-2014
ESB-TAR11 Dodge Charger, 2011-2014 and Ford Police Interceptor Sedan, 2013-2014
ESB-F113 Ford 150, 2013
ESB-TAH15 Chevrolet Tahoe, 2015
ESBMT-SB Bumper/Surface mount bracket
ESFMT Recess mount, polished trim ring
ESFMT-EF Recess mount, stainless steel "Electric F" grille



Flush mount with grille,
ESFMT-EF

Factory Set Specifications	
Housing Material	Compostie plastic (30% glass-filled PET)
Operating Temperatre	-40°C to +80°C
Power	100-Watts
Sound Output	SAE J1849 CCR Title 13
Physical Dimensions	
Height	5.5 in (14 cm)
Width	5.9 in (15 cm)
Depth	2.3 in (5.8 cm)
Shipping Weight	5.3 lbs (2.4 kg)
Speaker-only	5.0 lbs (2.3 kg)

Dimensional Diagrams

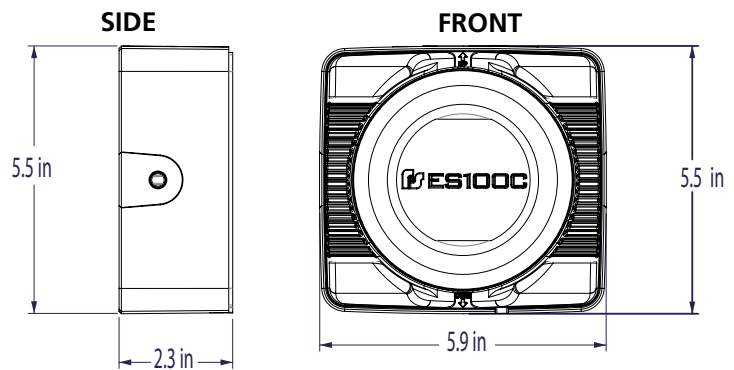

ESB-U



ESB-V08



ESB-TAH08



ESB-IMP08R



ESB-EXP07



ESB-CAP11



ESB-TAR11



ESB-F113



ESB-TAH15

Warning: Sirens and Speakers may produce LOUD sounds necessary to request the right-of-way. Sirens and Speakers may cause hearing damage. Wear hearing protection.

DynaMax is a trademark of Federal Signal Corporation.



2645 Federal Signal Drive, University Park, IL 60484
 Tel.: (800) 264-3578 • Fax: (800) 682-8022
 www.fedsig.com