



**Foco de LEDS modo día/noche
sin intermitencia**

**LED light head day/night mode
without flash**

QuadraFlare Advance CL2

refs. 2010617-18-23-24

FEDERAL SIGNAL VAMA, S.A.

C/Dr.Ferrán,7(08339)VILASSAR DE DALT - SPAIN

Tel: (34) 93.741.79.00

Telefax: (34) 93.753.03.62

WEB: www.fedsigvama.com



(E) Contenido

(GB) Contents

(E) Quadraflare Advance CL2, modo día/noche, sin intermitencia

(GB) Quadraflare Advance CL2, day/night mode, without flash

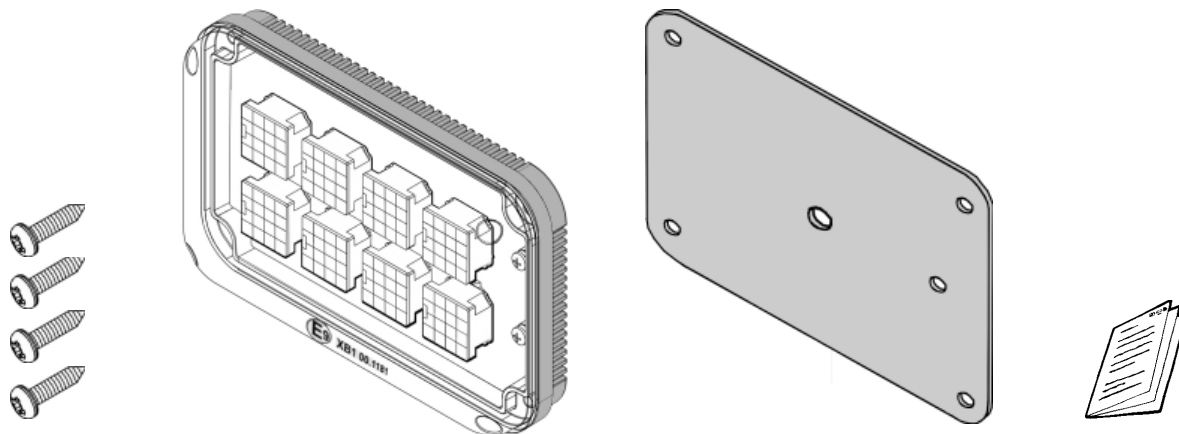

(E) Modelos

(GB) Models

QuadraFlare Advance CL2

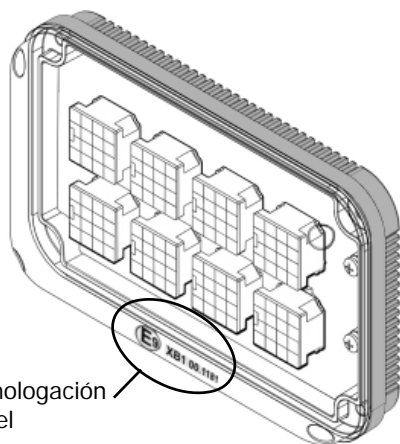

Etiqueta homologación
Approval label

R-65 approval
(E) Foco homologado por la norma europea R-65
(GB) Light approved by R-65 European Norm

ref.		color / colour						R65 CL2
		azul blue	ámbar amber	rojo red	blanco white	verde green	cristal clear	Homologación Approval
2010617	LED	X						
	lente/lens						X	X
2010618	LED	X						
	lente/lens	X						X
2010623	LED			X				
	lente/lens			X				X
2010624	LED			X				
	lente/lens			X			X	X

(E) FLASHER MODO INTERMITENCIA (GB) FLASH PATTERN FLASHER

MLP-F4
1x ref. 2006035

4 x 

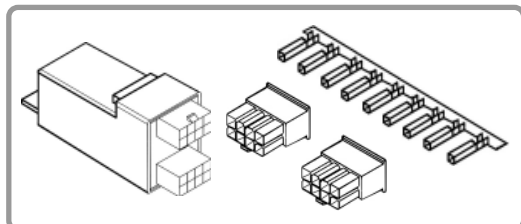

MLP-F8
1x ref. 2006030

8 x 

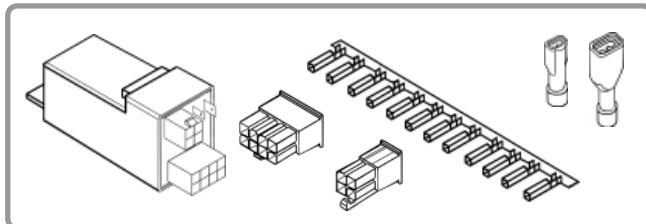

(E) KITS DE MONTAJE (opcional)

(GB) MOUNTING KITS (optional)

QL64MB (Superficie, negro / surface, black)
1 x ref. QL64MB

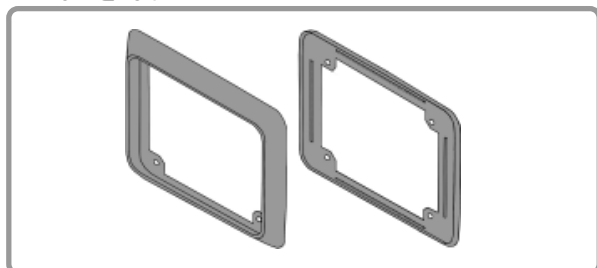

QL64MC (Superficie, cromado / surface, chrome)
1 x ref. QL64MC

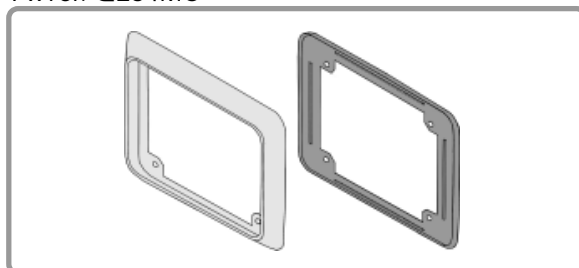

(E) ESPECIFICACIONES

(GB) SPECIFICATIONS

QuadraFlare Advance CL2

Alimentación <i>Voltage</i>	Multivoltaje 10-30V <i>Multivoltage 10-30V</i>
Temperatura de funcionamiento <i>Use temperature</i>	-20° / + 50°C
Consumo medio modo fijo <i>Steady burn mode average consumption</i>	1 A 12V / 0,7 A 24V
Consumo medio modo flash <i>Flash mode average consumption</i>	0,5 A 12V / 0,4 A 24V
Consumo medio crucero <i>Cruise average consumption</i>	0,1 A 12/24V
Color del Led <i>Led colour</i>	Ámbar / azul / rojo / verde / blanco Amber / blue / red /green /white
Tecnología <i>Technology</i>	Advance
Color de lente <i>Lens colour</i>	Ámbar / azul / rojo / cristal / verde Amber / blue / red / clear / green
Dimensiones (mm) <i>Dimensions (mm)</i>	167 x 107 x 38
Peso (gr) <i>Weight (gr)</i>	255

Flasher

Alimentación <i>Voltage</i>	Multivoltaje 10-30V <i>Multivoltage 10-30V</i>
Temperatura de funcion: <i>Use temperature</i>	-20° / + 50°C
Consumo medio <i>Average consumption</i>	0,02 A 10-30V
Dimensiones (mm) <i>Dimensions (mm)</i>	92 x 36 x 30
Peso (gr) <i>Weight (gr)</i>	35



E ADVERTENCIA:

QuadraFlare Advance ha sido diseñado para su instalación con junta de montaje (ver fig.1), el kit de montaje QL64MB (ver fig.2) o el kit de montaje QL64MC (ver fig.3). Cualquier otro sistema de montaje puede causar daños en el foco.

GB WARNING:

QuadraFlare Advance has been designed for installation with mounting joint (see fig.1), QL64MB mounting kit (see fig.2) or QL64MC mounting kit (see fig.3). Any other mounting system can be cause damage in the light.

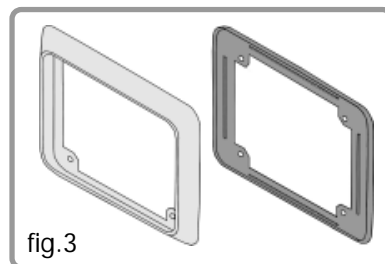
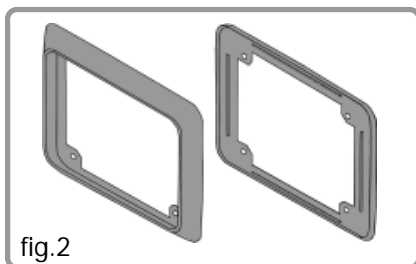
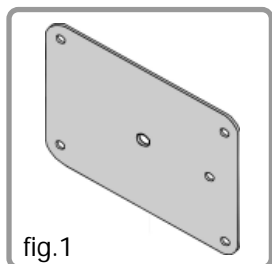

E ADVERTENCIA:

Para cumplir con la Norma Europea R-65:

- El foco QuadraFlare Advance, lente lisa, led azul, lente azul o cristal, ha de instalarse horizontalmente (ver fig.4).
- Los focos QuadraFlare Advance han de conectarse al flasher MLP-F4 o MLP-F8 (ver fig.5).
- El flasher MLP-F4 / MLP-F8 ha de estar programado en modo de intermitencia R-65 (fig.6).

GB WARNING:

To comply with R-65 European Standard:

- QuadraFlare Advance light, smooth lens, blue led, blue or clear lens, has been installed horizontally (see fig.4).
- QuadraFlare Advance lights must be connected to MLP-F4 or MLP-F8 flasher (see fig.5).
- MLP-F4 or MLP-F8 flasher must be programmed with R-65 flash pattern (see fig.6).

QuadraFlare Advance

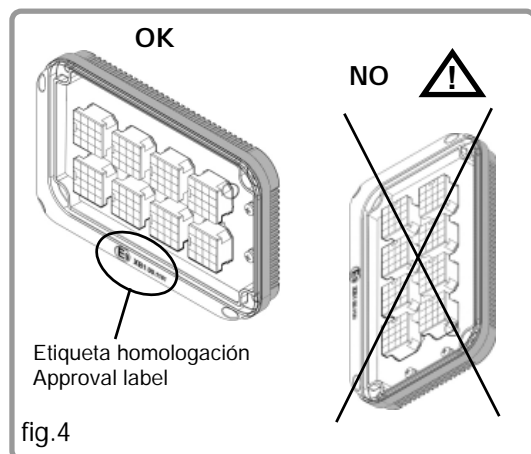

Flasher

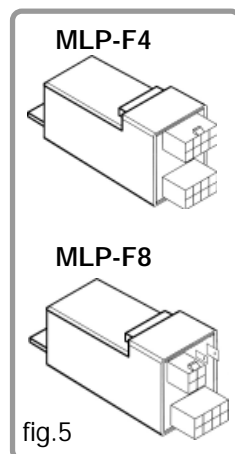

R-65

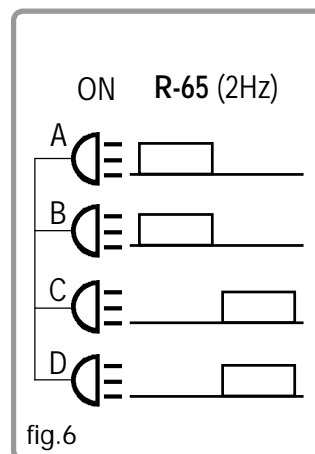

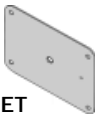

(E) Material necesario (no suministrado)

(GB) Necessary material (not supplied)

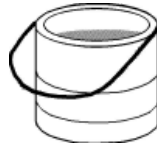
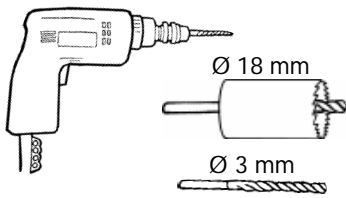

(E) Nitrato de zinc
(GB) Zinc nitrate

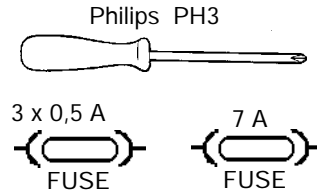

(E) Instrucciones de instalación

(GB) Installation instructions

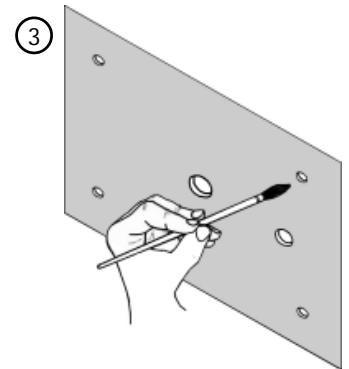
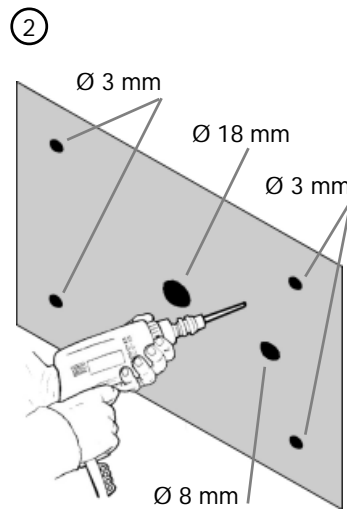
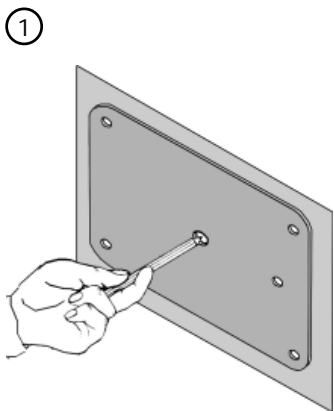

(E) Nitrato de zinc
(GB) Zinc nitrate
(F) Nitrate de zinc
(D) Zinknitrat
(I) Nitrato di zinco

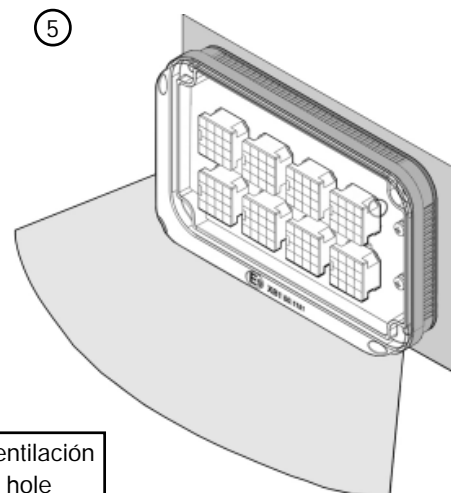
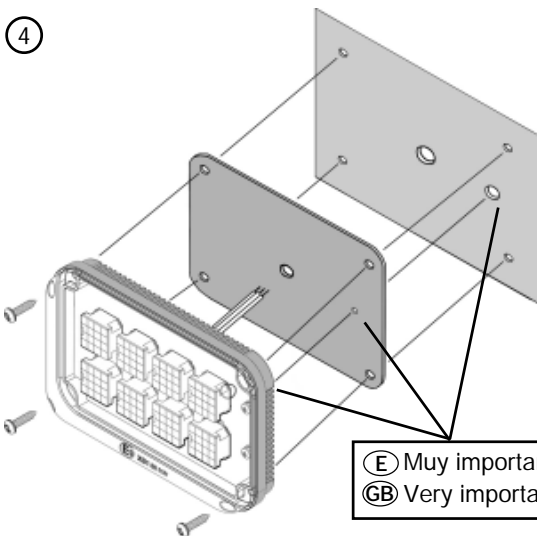

(E) Muy importante: taladro ventilación
(GB) Very important: ventilation hole

QL64MB

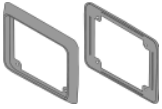

QL64MC

(E) INSTALACIÓN

(GB) INSTALLATION

(E) Material necesario (no suministrado)

(GB) Necessary material (not supplied)

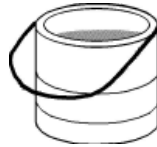
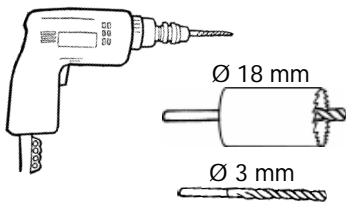

(E) Nitrato de zinc
(GB) Zinc nitrate

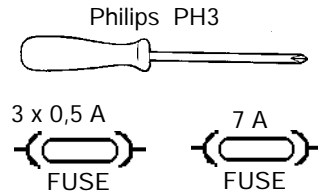

(E) Instrucciones de instalación

(GB) Installation instructions

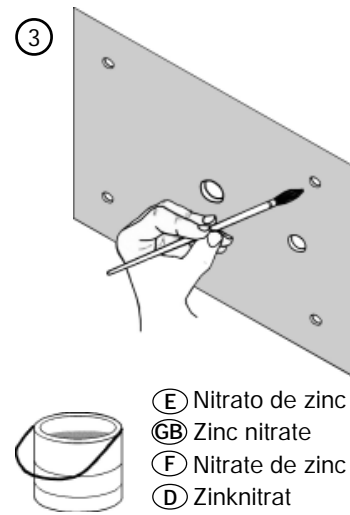
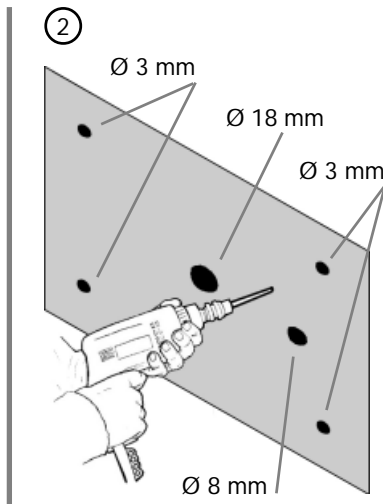
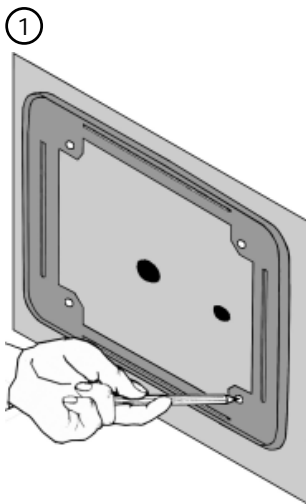

(E) Nitrato de zinc
(GB) Zinc nitrate
(F) Nitrate de zinc
(D) Zinknitrat
(I) Nitrato di zinco

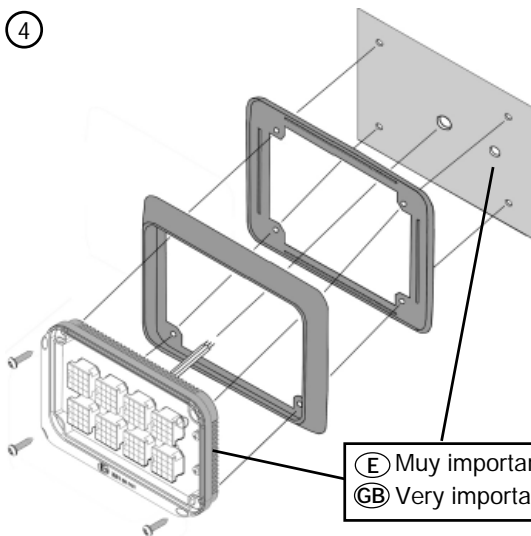

(E) Muy importante: taladro ventilación
(GB) Very important: ventilation hole

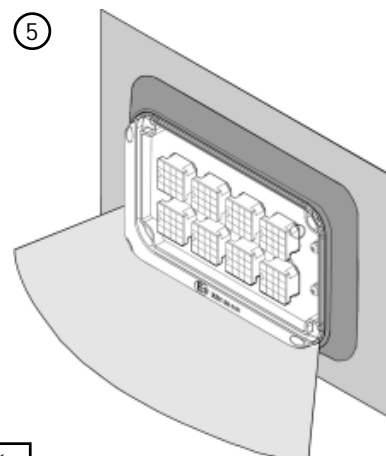

(E) Cableado, interruptores y fusible NO incluidos. Se recomienda usar el interruptor SW-521 o similares.

(GB) Wiring, switches and fuse NOT included. It is recommended to use SW-521 switch or similar.

Flasher MLP-F4 ref. 2006035 + 4 luces sincronizadas

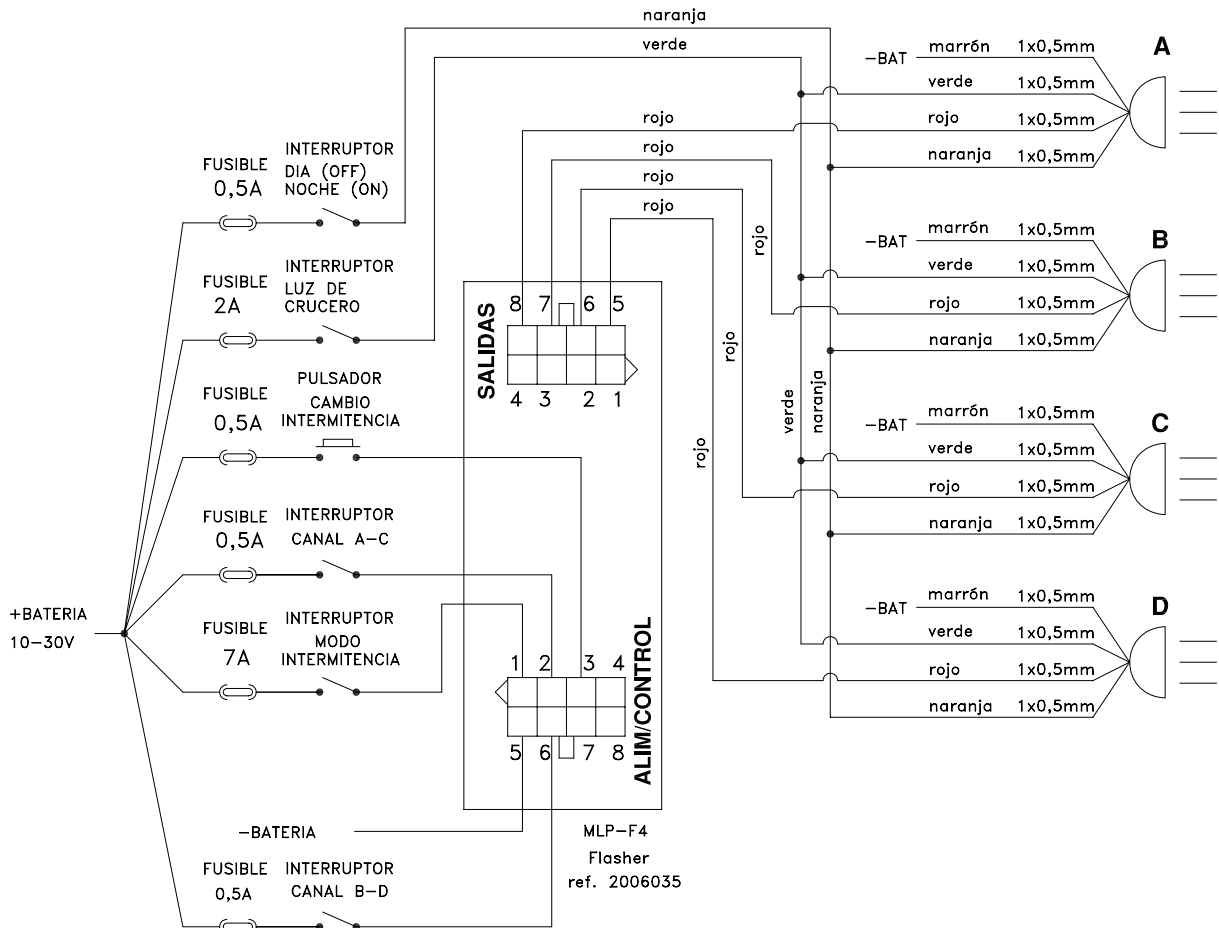

E	GB
BATERIA	BATTERY
CAMBIO INTERMITENCIA	FLASH CHANGE
CANAL	CHANNEL
DIA	DAY
FLASHER	FLASHER
FUSIBLE	FUSE
INTERRUPTOR	SWITCH
LUCES SINCRONIZADAS	SYNCHRONIZED LIGHTS
LUZ DE CRUCERO	CRUISE LIGHT
MARRON	BROWN
MODO INTERMITENCIA	FLASH PATTERN
NARANJA	ORANGE
NOCHE	NIGHT
ON/OFF	ON/OFF
PULSADOR	PUSH-BUTTON
ROJO	RED
VERDE	GREEN

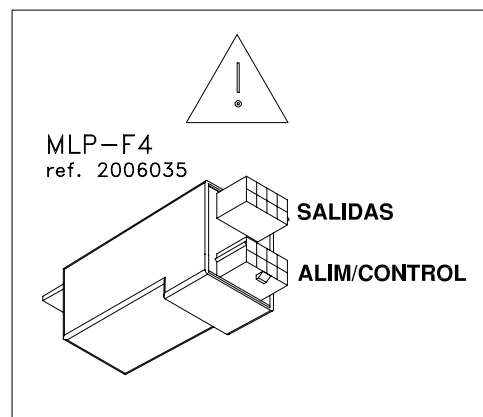

(E) Cableado, interruptores y fusible NO incluidos. Se recomienda usar el interruptor SW-521 o similares.

(GB) Wiring, switches and fuse NOT included. It is recommended to use SW-521 switch or similar.

Flasher MLP-F8 ref. 2006030 + 8 luces sincronizadas

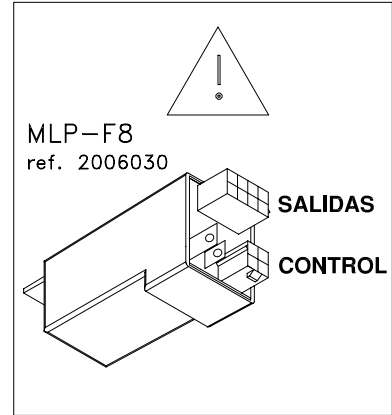
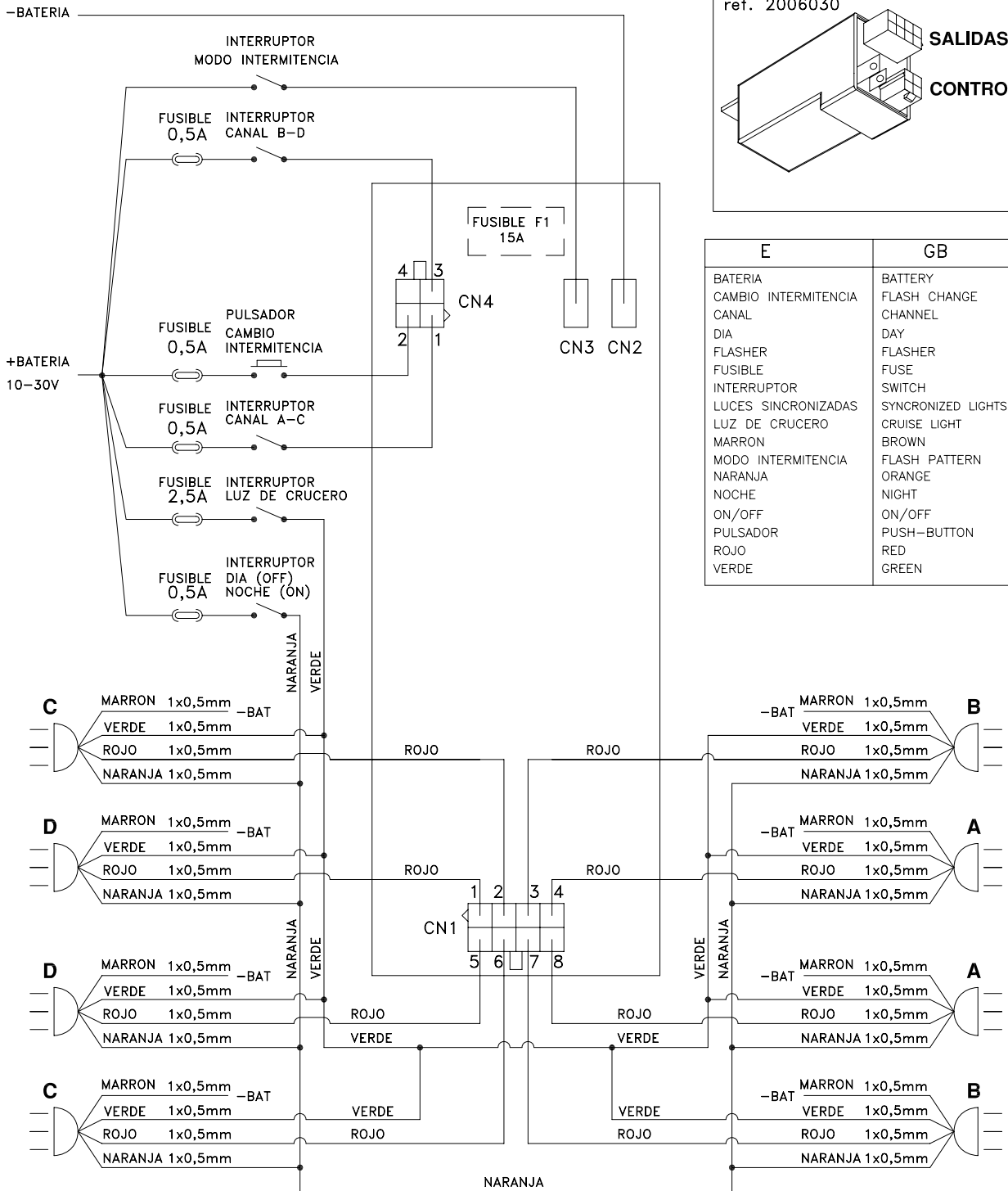

E	GB
BATERIA	BATTERY
CAMBIO INTERMITENCIA	FLASH CHANGE CHANNEL
CANAL	CHANNEL
DIA	DAY
FLASHER	FLASHER
FUSIBLE	FUSE
INTERRUPTOR	SWITCH
LUCES SINCRONIZADAS	SYNCHRONIZED LIGHTS
LUZ DE CRUCERO	CRUISE LIGHT
MARRON	BROWN
MODO INTERMITENCIA	FLASH PATTERN
NARANJA	ORANGE
NOCHE	NIGHT
ON/OFF	ON/OFF
PULSADOR	PUSH-BUTTON
ROJO	RED
VERDE	GREEN

(E) Cableado, interruptores y fusible NO incluidos. Se recomienda usar el interruptor SW-521 o similares.

(GB) Wiring, switches and fuse NOT included. It is recommended to use SW-521 switch or similar.

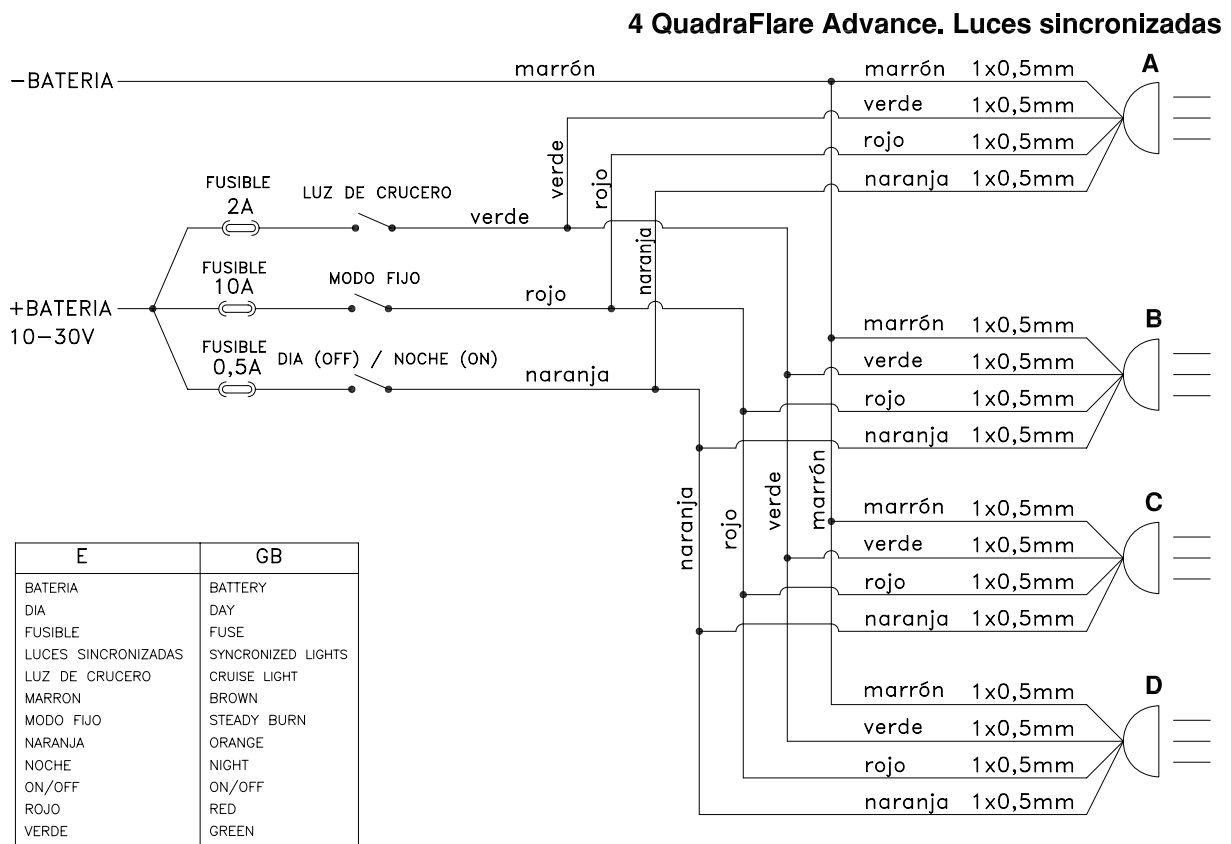
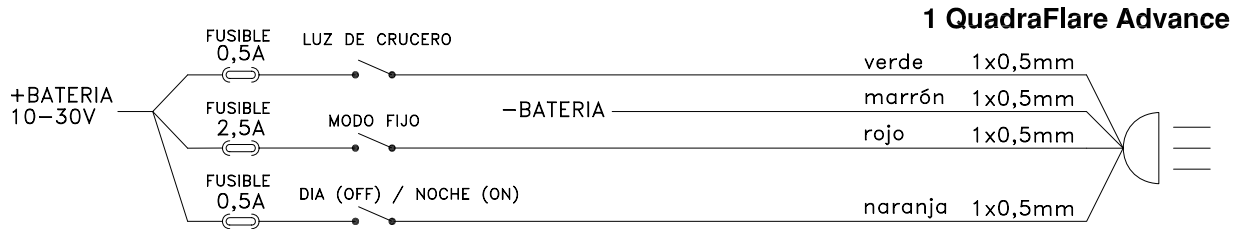

(E) **QuadraFlare Advance es un foco fijo que puede ser conexionado con otros equipos como: Controladores SMC (Signalmaster), Sistemas ICS2000 (ICS2004, ICS2006, ICS2009, ICS2010,...), sirenas Serie 400 y 300, Intelliflash, relés de intermitencia FA3,...**

Para obtener más información póngase en contacto con nuestro departamento comercial.

IMPORTANTE: La conexión a estos equipos sin el flasher MLP-F4 o MLP-F8 anulará la homologación R-65.

(GB) **QuadraFlare Advance is a steady burn light, which can be connected to other equipments like as: SMC controls, ICS2000 Systems (ICS2004, ICS2006, ICS2009, ICS2010), 400 and 300 Series sirens, Intelliflash, FA3 intermittence relays...**

For more information, contact our sales department.

IMPORTANT: The connection to these equipments without the MLP-F4 or MLP-F8 flasher invalidate the R-65 approval.

1

E

Intermitencia OFF
 Canal A-C OFF
 Canal B-D OFF
 Luz Crucero OFF
 Cambio Intermitencia OFF
 Día/Noche OFF

GB

OFF Flash Pattern
 OFF A-C Channel
 OFF B-D Channel
 OFF Cruise Light
 OFF Flash Patern Change
 OFF Day/Night

2

E Quadraflare Advance desactivado (OFF)
GB Deactivated Quadraflare Advance (OFF)



3

E

Intermitencia **ON**
 Canal A-C OFF
 Canal B-D OFF
 Luz Crucero OFF
 Cambio Intermitencia OFF
 Día/Noche OFF

GB

ON Flash Pattern
 OFF A-C Channel
 OFF B-D Channel
 OFF Cruise Light
 OFF Flash Patern Change
 OFF Day/Night

4

E Luz activada modo intermitencia
GB Flash patern activated light

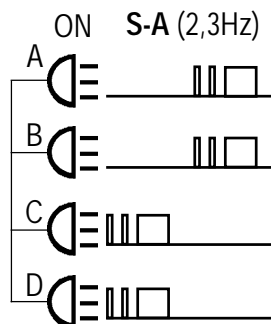

5

E

Intermitencia ON
 Canal A-C **ON**
 Canal B-D OFF
 Luz Crucero OFF
 Cambio Intermitencia OFF
 Día/Noche OFF

GB

OFF Flash Pattern
ON A-C Channel
 OFF B-D Channel
 OFF Cruise Light
 OFF Flash Patern Change
 OFF Day/Night

6

E Canal A-C desactivado
GB Deactivated A-C channel

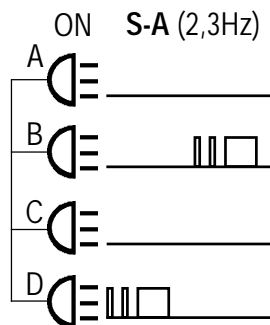

7

E

Intermitencia ON
 Canal A-C OFF
 Canal B-D **ON**
 Luz Crucero OFF
 Cambio Intermitencia OFF
 Día/Noche OFF

GB

ON Flash Pattern
 OFF A-C Channel
ON B-D Channel
 OFF Cruise Light
 OFF Flash Patern Change
 OFF Day/Night

8

E Canal B-D desactivado
GB Deactivated B-D channel

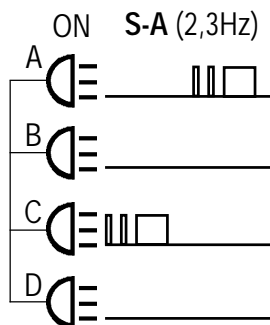

1

(E)

Intermitencia OFF
 Canal A-C OFF
 Canal B-D OFF
 Luz Crucero OFF
 Cambio Intermitencia OFF
 Día/Noche OFF

(GB)

OFF Flash Pattern
 OFF A-C Channel
 OFF B-D Channel
 OFF Cruise Light
 OFF Flash Patern Change
 OFF Day/Night

2

(E) Quadraflare Advance desactivado (OFF)

(GB) Deactivated Quadraflare Advance (OFF)



3

(E)

Intermitencia OFF
 Canal A-C OFF
 Canal B-D OFF
 Luz Crucero **ON**
 Cambio Intermitencia OFF
 Día/Noche OFF

(GB)

OFF Flash Pattern
 OFF A-C Channel
 OFF B-D Channel
ON Cruise Light
 OFF Flash Patern Change
 OFF Day/Night

4

(E) Luz activada modo Luz Crucero

(GB) Cruise Light mode activated light

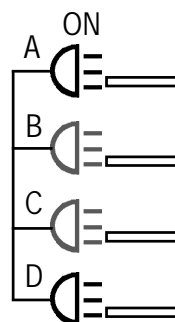

5

(E)

Intermitencia OFF
 Canal A-C OFF
 Canal B-D OFF
 Luz Crucero **ON**
 Cambio Intermitencia OFF
 Día/Noche OFF

(GB)

OFF Flash Pattern
 OFF A-C Channel
 OFF B-D Channel
ON Cruise Light
 OFF Flash Patern Change
 OFF Day/Night

6

(E)

Intermitencia **ON**
 Canal A-C OFF
 Canal B-D OFF
 Luz Crucero ON
 Cambio Intermitencia OFF
 Día/Noche OFF

(GB)

ON Flash Pattern
 OFF A-C Channel
 OFF B-D Channel
 ON Cruise Light
 OFF Flash Patern Change
 OFF Day/Night

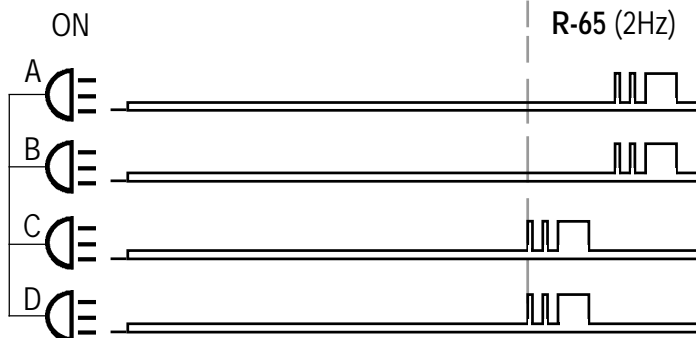

S-A
 (2,3Hz)
(E) Por defecto
(GB) Default

1

(E)

Intermitencia ON
 Canal A-C OFF
 Canal B-D OFF
 Luz Crucero OFF
 Cambio Intermitencia OFF
 Día/Noche **ON**

(GB)

ON Flash Pattern
 OFF A-C Channel
 OFF B-D Channel
 OFF Cruise Light
 OFF Flash Patern Change
ON Day/Night

2

Luz activada modo Noche
 Night mode activated light

ON S-A (2,3Hz)

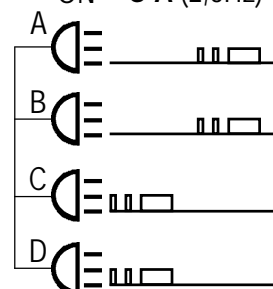

1

(E)
Intermitencia ON
Cambio Intermitencia **ON**

(GB)
ON Flash Pattern
ON Flash Patern Change

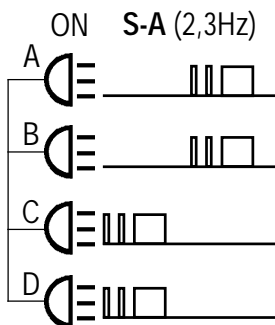

2

(E)
Intermitencia ON
Cambio Intermitencia **ON**

(GB)
ON Flash Pattern
ON Flash Patern Change

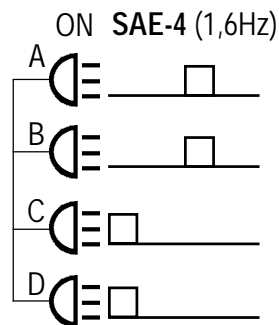

3

(E)
Intermitencia ON
Cambio Intermitencia **ON**

(GB)
ON Flash Pattern
ON Flash Patern Change

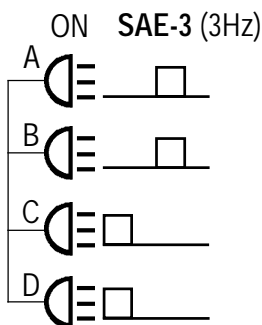

4

(E)
Intermitencia ON
Cambio Intermitencia **ON**

(GB)
ON Flash Pattern
ON Flash Patern Change

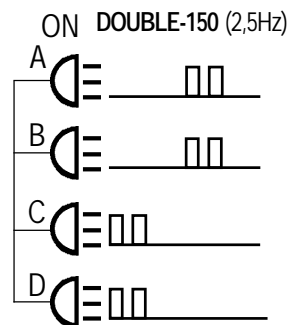

5

(E)
Intermitencia ON
Cambio Intermitencia **ON**

(GB)
ON Flash Pattern
ON Flash Patern Change

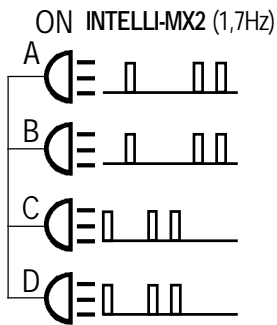

6

(E)
Intermitencia ON
Cambio Intermitencia **ON**

(GB)
ON Flash Pattern
ON Flash Patern Change

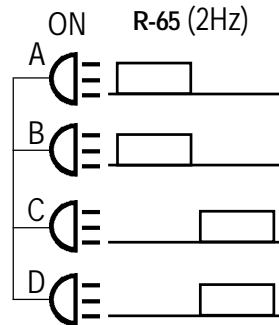

7

(E)
Intermitencia ON
Cambio Intermitencia **ON**

(GB)
ON Flash Pattern
ON Flash Patern Change

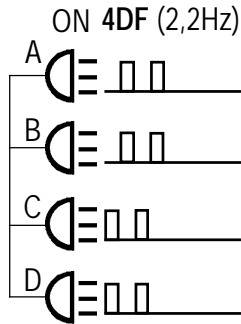

8

(E)
Intermitencia ON
Cambio Intermitencia **ON**

(GB)
ON Flash Pattern
ON Flash Patern Change

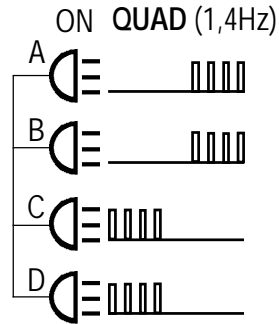

⑧ → ①

QuadraFlare Advance

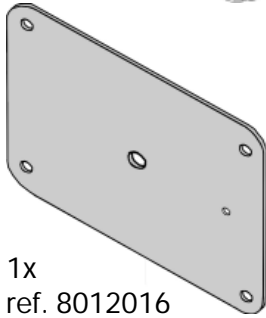
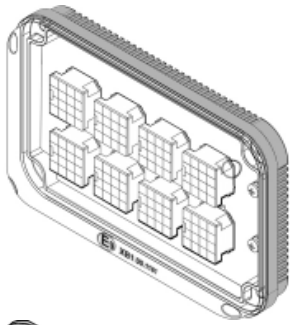

1x
ref. 8012016

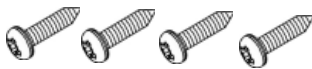

4x
ref. 9027245

R-65 approval
 (E) Foco homologado por la norma europea R-65
 (GB) Light approved by R-65 European Norm

ref.		color / colour						R65 CL2
		azul blue	ámbar amber	rojo red	blanco white	verde green	cristal clear	Homologación Approval
2010617	LED	X						
	lente/lens						X	X
2010618	LED	X						
	lente/lens	X						X
2010623	LED			X				
	lente/lens			X				X
2010624	LED			X				
	lente/lens						X	X

QL64MB
 (Superficie, negro / Surface, black)
 1 x ref. QL64MB

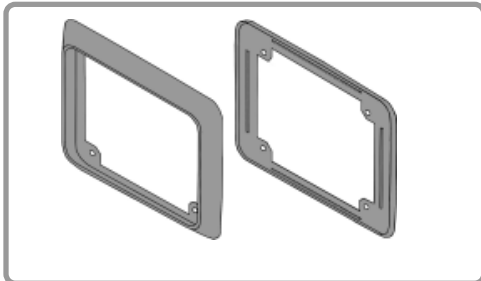

QL64MC
 (Superficie, cromado / Surface, chrome)
 1 x ref. QL64MC

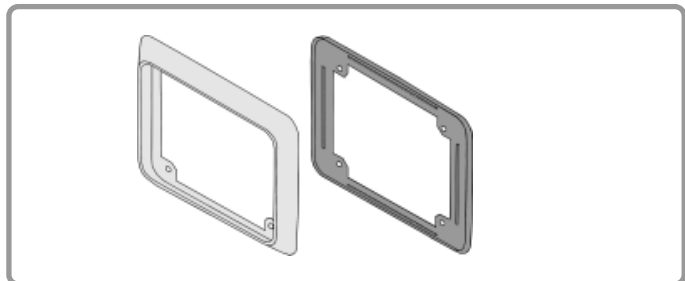

MLP-F4
 flasher
 1x ref. 2006035

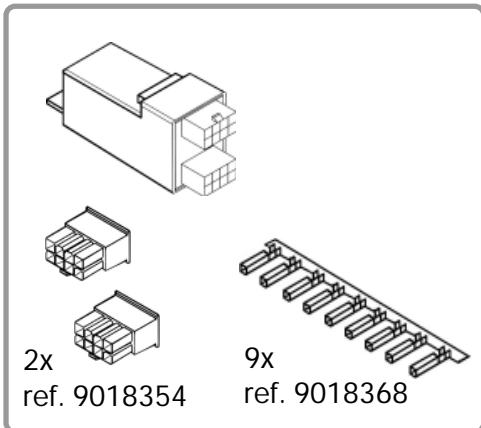

2x
ref. 9018354

9x
ref. 9018368

MLP-F8
 flasher
 1x ref. 2006030

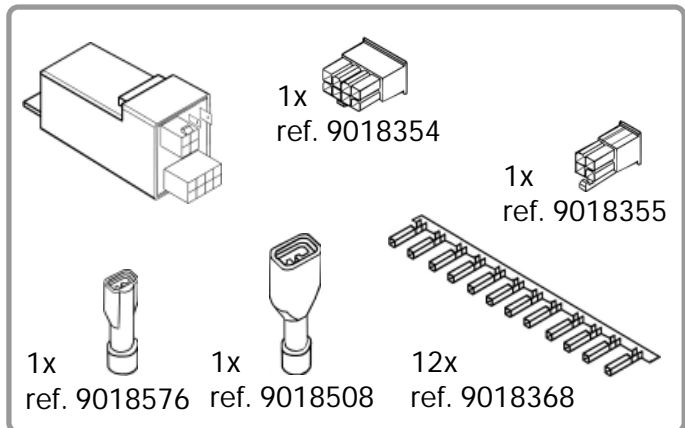

1x
ref. 9018354

1x
ref. 9018355

1x
ref. 9018576

1x
ref. 9018508

12x
ref. 9018368



MENSAJE DE SEGURIDAD PARA EL INSTALADOR

La vida de las personas depende de una instalación adecuada y segura de nuestros productos. Es importante que Vd. lea, comprenda y siga atentamente todas las instrucciones que se acompañan a este producto y sus productos complementarios. Además, a continuación le relacionamos una serie de instrucciones de seguridad y precauciones importantes que Vd. debería observar:

- Para instalar adecuadamente este equipo: Vd. debe tener un buen conocimiento de electricidad del automóvil, además de formación en la instalación y utilización de equipos de Seguridad.
- Cuando proceda a taladrar la estructura o chapa del vehículo, asegúrese de que ambos lados de la superficie se encuentran libres de cualquier elemento que pudiera resultar dañado. Limpie los agujeros realizados de cualquier resto de material que haya podido quedar. Para prevenir cortocircuitos, se aconseja usar pasacables aislantes en los agujeros por donde pase el cable.
- Luz / sonido es un dispositivo por el que circula una intensidad alta de corriente. Para que pueda funcionar adecuadamente, debe instalarse una conexión separada a masa. En el caso de que sea posible, aconsejamos conectarlo al terminal negativo de la batería. Como mínimo debería fijarse a un elemento metálico sólido o a una parte del chasis, que proporcionen un paso a masa efectivo cuando el equipo sea utilizado.
- Se producen voltajes altos dentro de los modelos equipados con luces estroboscópicas durante y después de su funcionamiento. Asegúrese de que la fuente de alimentación se encuentra desconectada y espere al menos DIEZ MINUTOS antes de desmontar la lente de la luz.
- Disponga los equipos de modo que el VEHÍCULO y los CONTROLES puedan ser manejados con seguridad bajo cualquier condición de conducción.
- Vd. debería revisar frecuentemente los equipos para asegurar que funcionan adecuadamente y que se encuentran convenientemente fijados al vehículo.
- Conserve estas instrucciones en un lugar seguro y remítase a ellas cuando efectúe operaciones de mantenimiento o reinstale el producto.

El no cumplimiento de estas normas de precaución puede dar como resultado daños a la propiedad, lesiones graves o muerte tanto para Vd. como para otras personas.



SAFETY MESSAGE TO INSTALLERS

People's lives depend on your safe installation of our products. It is important to read, understand and follow all instructions shipped with this product and the related add-on products. In addition, listed below are some other important safety instructions and precautions you should follow:

- To properly install this product: you must have a good understanding of automotive electrical procedures and systems, along with proficiency in the installation and use of safety warning equipment.
 - When drilling into a vehicle structure, be sure that both sides of the surface are clear of anything that could be damaged. Remove all burrs from drilled holes. To prevent electrical shorts, grommet all drilled holes through which wiring passes.
 - A light / sound system is a high current device. In order for it to function properly, a separate ground connection must be made. If practical, it should be connected to the negative battery terminal. At a minimum, it may be attached to a solid metal body or chassis part that will provide an effective ground path as long as the equipment is to be used.
 - High voltages are present inside the strobe light equipped models during and after operation. Ensure that power is disconnected and wait at least ten minutes before removing the dome.
 - Locate the equipment so the VEHICLE and CONTROLS can be operated safely under all driving conditions.
 - You should frequently inspect the equipment to ensure that it is operating properly and that it is securely attached to the vehicle.
 - File these instructions in a safe place and refer to them when maintaining and reinstalling the product.
- Failure to follow all safety precautions and instructions may result in property damage, serious injury, or death to you or to others.